

in[mm]

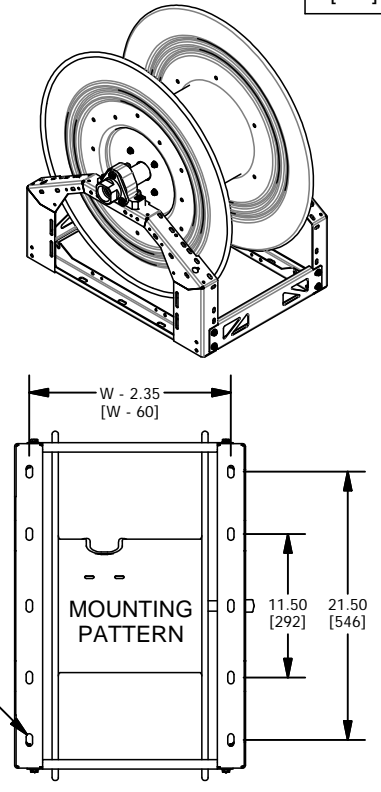
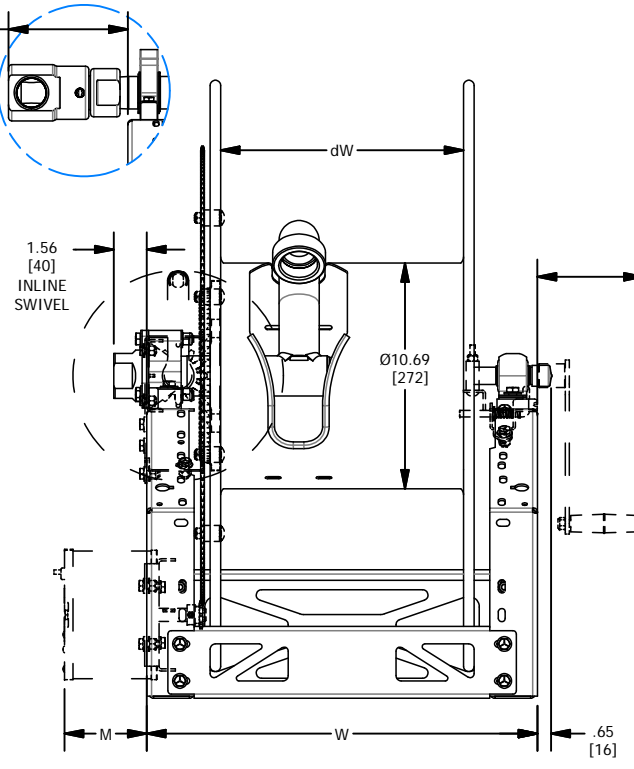
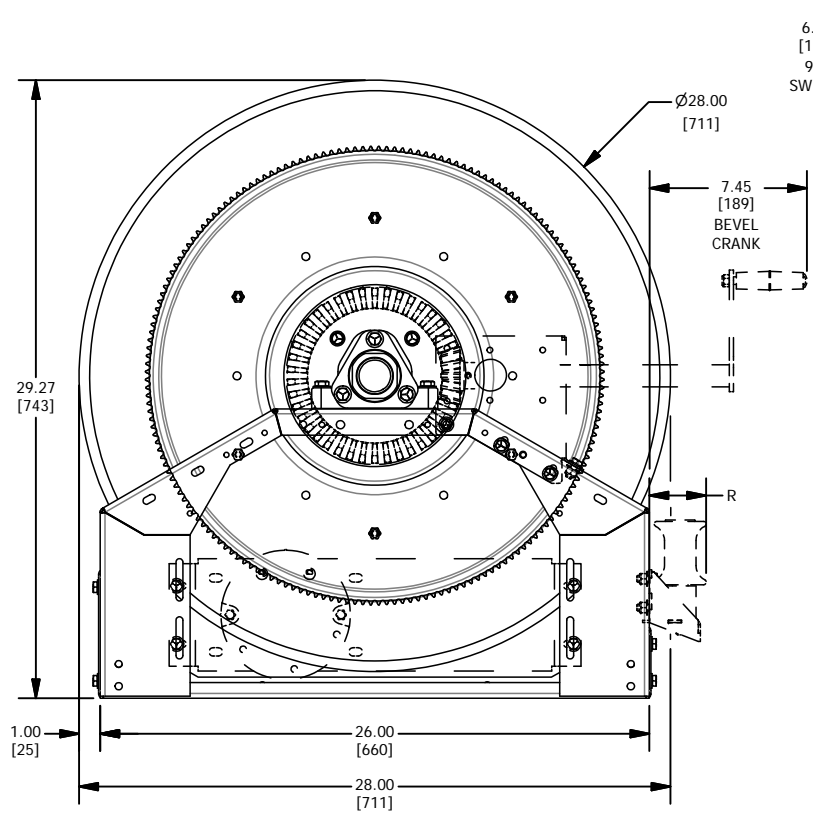

DIMENSION M in[mm]					
MOTOR DRIVE SYSTEM	DIRECT DRIVE	+ IDLER GEAR	+ CLUTCH	+ IDLER & CLUTCH	DRIVE OPTIONS
ELECTRIC MOTOR: 1/3 HP (12VDC,24VDC)	4.25 [110]	5.00 [130]	4.25 [110]	5.00 [130]	IDLER GEAR 1:2, 1:3, 1:4 RATIO
ELECTRIC MOTOR: 1/2 HP (12VDC,24VDC,115VAC,230VAC)	6.00 [150]	6.88 [175]	6.88 [175]	7.88 [200]	CENTRIFUGAL CLUTCH
AIR MOTOR (4 VANE, ALUMINUM)	3.13 [80]	4.13 [105]	-	-	EXTERNAL SHAFT FOR BRAKES (ELECTRO-MAG. OR 3-WAY BRAKE)
AIR MOTOR (6 VANE, IRON)	4.75 [120]	-	-	-	EXTERNAL SHAFT FOR BRAKES
HYDRAULIC	2.88 [75]	3.75 [95]	-	-	EXTERNAL SHAFT FOR BRAKES

DIMENSION R in[mm]	
ROLLER TYPE	DIM "R"
4-WAY ROLLERS	.82 [21]
UNIVERSAL 4-WAY ROLLERS	1.21 [31]
3-WAY ROLLERS	2.76 [70]
UNIVERSAL 3-WAY ROLLERS	3.15 [80]

MATERIAL SPECIFICATIONS		
COMPONENT	MATERIAL	OPTIONS
PLUMBING	ZINC PLATED STEEL	316 STAINLESS STEEL
SWIVEL	NI PLATED STEEL (INLINE)	316 STAINLESS STEEL INLINE OR 90°, 90° NI PLATED STEEL
SEALS	NITRILE	VITON, EPDM
REEL	STEEL	-
BEARINGS	BRONZE & TEFLON INFUSED PLATING	-
DRAG BRAKE	NYLON	BRAKE PAD MATERIAL
CHAIN GUARD	STEEL	ABS
FINISH	BLUE POWDER COAT	RED, GREEN, WHITE, BLACK, GREY

MODEL	dW in[mm]	W in[mm]	1.5" (2.06" OD) CAPACITY ft[m]	1.25" (1.81" OD) CAPACITY ft[m]	SHIPPING WEIGHT lb[kg]
1680-0828	8 [200]	15 [380]	50 [15]	80 [25]	88 [40]
1680-0928	9.5 [240]	16.5 [420]	70 [20]	100 [30]	90 [41]
1680-1128	11.5 [290]	18.5 [470]	90 [25]	125 [35]	93 [42]
1680-1328	13.5 [340]	20.5 [520]	100 [30]	150 [45]	96 [44]
1680-1528	15.5 [390]	22.5 [570]	125 [35]	175 [50]	99 [45]
1680-2028	20 [510]	27 [690]	150 [45]	225 [65]	105 [48]
1680-2228	22 [560]	29 [740]	180 [55]	250 [75]	108 [49]
1680-2428	24 [610]	31 [790]	200 [60]	275 [84]	111 [50]
1680-2528	25 [640]	32 [815]	210 [65]	285 [86]	113 [51]
1680-2828	28 [710]	35 [890]	225 [70]	300 [90]	118 [54]
1680-3328	33 [840]	40 [1020]	275 [85]	350 [105]	126 [57]

PART NUMBER

DRUM WIDTH — DISK SIZE — ROLLERS & SETUP

16 80 - 15 28 - XX - B X XX

PLUMBING SIZE: 60 = 1", 80 = 1.5"

MOTOR, CRANK & BRAKE OPTIONS

PLUMBING & SWIVEL OPTIONS

SPECIFICATIONS		OPTIONS
PRESSURE	1500 PSI [100 BAR]	3000 PSI [200 BAR]
TEMPERATURE	-40 F TO 275 F [-40 C TO 135 C]	-60 F [-50 C] EPDM 400F [240 C] VITON
INLET THREAD	1.5" NPT FEMALE	1.5" BSPT FEMALE
OUTLET THREAD	1.5" NPT FEMALE	1.5" NPT MALE, BSPP FEMALE, BSPT MALE, NST

UNLISTED OPTIONS & CUSTOM REELS

NOT ALL OPTIONS ARE LISTED, CONTACT YOUR SALES REPRESENTATIVE OR FACTORY FOR ADDITIONAL OPTIONS & CUSTOM MODIFICATIONS

COXREELS

5865 S Ash Avenue Tempe, Az 85283
1-800-COX-REEL www.coxreels.com

THIS DOCUMENT CONTAINS PROPRIETARY INFORMATION AND IS THE PROPERTY OF COXREELS, INC. THE COPYING, DISTRIBUTION AND UTILIZATION OF THIS DOCUMENT AS WELL AS COMMUNICATION OF ITS CONTENT TO OTHERS WITHOUT THE WRITTEN AUTHORIZATION OF COXREELS, INC., IS PROHIBITED.

TITLE: **1600 SERIES, 28" DISK, 1.5" PLUMBING**

DWG. NO.: 1680-XX28

REV. **B**

3RD ANGLE

INTERPERT PER ASME : Y14.5M-1994 DO NOT SCALE DWG.

SIZE: A

SHT:1 OF:2

ROLLER BRACKET OPTIONS

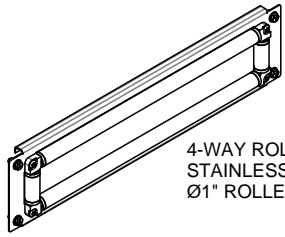

4-WAY ROLLERS
STAINLESS STEEL
Ø1" ROLLERS

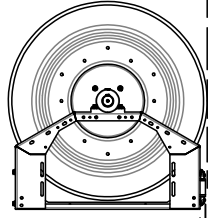

BOTTOM
4-WAY ROLLERS
←.74
[19]

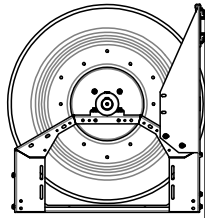

TOP
4-WAY ROLLERS
←.82
[21]

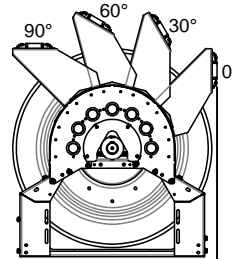

UNIVERSAL
4-WAY ROLLERS
←1.75
[44]

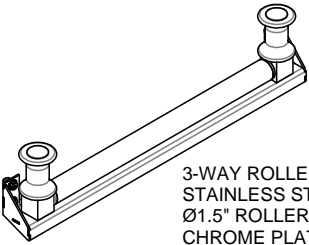

3-WAY ROLLERS
STAINLESS STEEL
Ø1.5" ROLLER
CHROME PLATED
STEEL SPOOLS

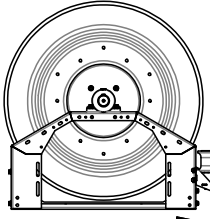

BOTTOM
3-WAY ROLLERS
←2.69
[68]

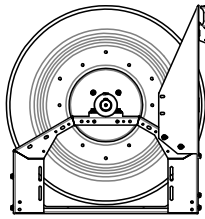

TOP
3-WAY ROLLERS
←2.76
[70]

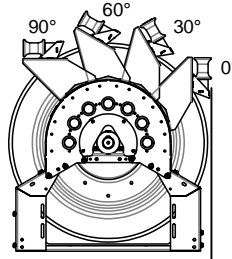

UNIVERSAL
3-WAY ROLLERS
←1.53
[39]

BEVEL CRANK UNIVERSAL OPTION

UNIVERSAL BEVEL CRANK MOUNT
ALLOWS FOR VARIOUS ANGLES
WORKS WITH OR WITH OUT 3 OR 4
WAY ROLLERS

in[mm]

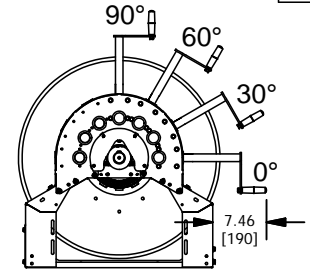
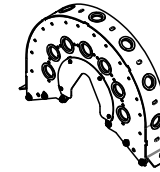

BEVEL CRANK HANDLE HOLSTER

HOLSTER INCLUDES RETAINING
PIN FOR AUXILIARY CRANKS &
MOUNTS TO ANY BEVEL MOUNT
BRACKET & DIRECTLY TO FRAME

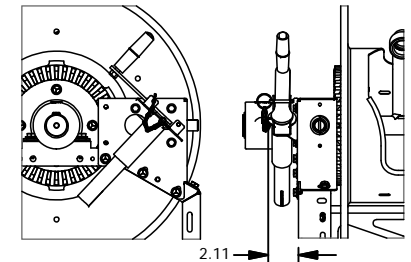
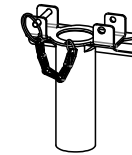

2.11
[54]

GUARDING OPTIONS

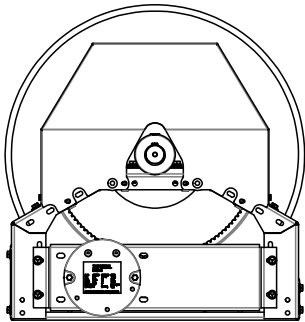

ABS FORMED OR METAL CHAIN &
BEVEL GEAR GUARDS DEPENDING
ON SPROCKET SIZE

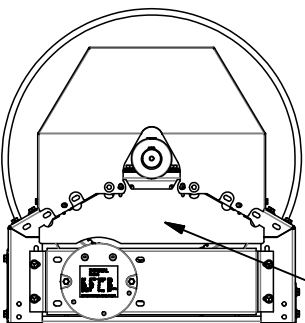
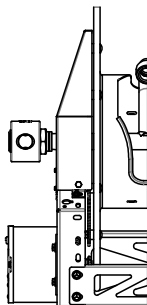

LOWER CHAIN GUARD COVERS
ACCESS TO CHAIN FROM OUTSIDE
AND INSIDE OF FRAME

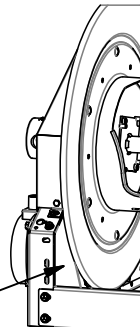

3-WAY PIN LOCK

(3 POSITION HEAVY DUTY PIN LOCK)

PATENT PENDING

¾" SOLID STEEL PIN
LOCKING EVERY 20°
EXTERNAL GREASE FITTING

3 POSITIONS

- 1) LOCKED REEL
- 2) FREE SPIN
- 3) LEVER ACTIVATED REWIND
(TRIGGERS ELECTRIC MOTOR REWIND)

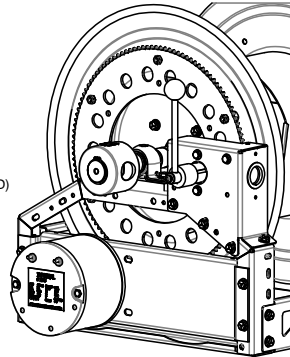
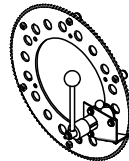

BRAKE UPGRADES

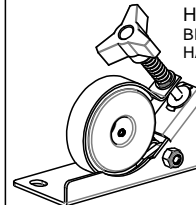

HEAVY DUTY BAND BRAKE
BRAKE PAD LINED BAND
HARDENED STEEL DRUM

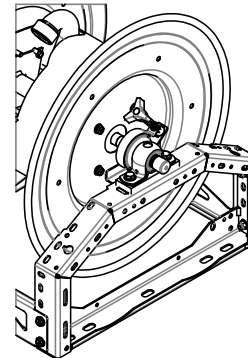

HEAVY DUTY
BAND BRAKE

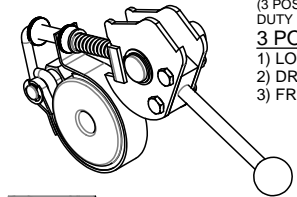

3-WAY BRAKE
(3 POSITION HEAVY
DUTY BAND BRAKE)
3 POSITIONS
1) LOCK REEL
2) DRAG BRAKE
3) FREE SPIN

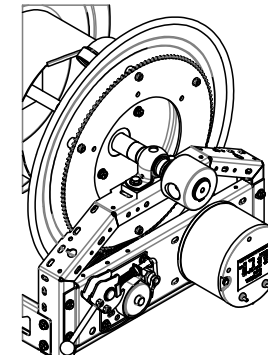

3-WAY BRAKE
ON IDLER SHAFT

CONTROL BOX

(NEMA 1 ENCLOSED ELECTRICAL BOX)

12VDC OR 24VDC
CIRCUIT BREAKER
MOTOR SOLENOID
MOMENTARY SWITCH
WIRE STRAIN RELIEFS

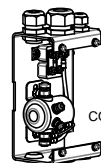

SHOWN WITH
COVER REMOVED

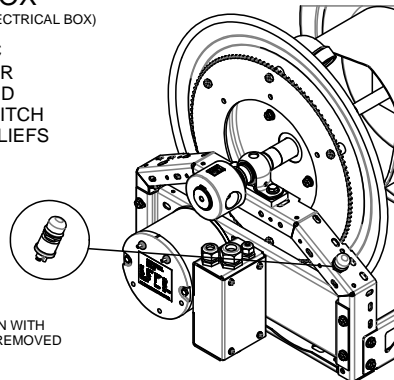

COXREELS

5865 S Ash Avenue Tempe, Az 85283
1-800-COX-REEL www.coxreels.com

THIS DOCUMENT CONTAINS PROPRIETARY
INFORMATION AND IS THE PROPERTY OF COXREELS,
INC. THE COPYING, DISTRIBUTION AND UTILIZATION
OF THIS DOCUMENT AS WELL AS COMMUNICATION
OF ITS CONTENT TO OTHERS WITHOUT THE WRITTEN
AUTHORIZATION OF COXREELS, INC., IS PROHIBITED.

TITLE: **1600 SERIES, OPTIONS &
ACCESSORIES**

DWG. NO.:	1680-XX28	REV.	B
3RD ANGLE	INTERPERT PER ASME : Y14.5M-1994 DO NOT SCALE DWG.	SIZE: A	SHT:2 OF:2